

TOTO®

Perfection by Design

AC Powered (120V AC to 10V DC) Sensor Toilet Flush Valve, Exposed

To be specified:

Sensor Toilet Flush Valve

- Valve only, Nickel Chrome Plated Finish
 - Left and Right Rough - TET1ANCR
- Complete Set, Nickel Chrome Plated Finish
 - Left and Right Rough - TET1ANCR-32 (1 1/2" V.B.)

Complete Set Supplied With:

- Vacuum Breaker & Angle Stop Set - VB9CP-32
 - 1" Angle Stop - 10077t3
 - 1 1/2" Vacuum Breaker - 10075t1
 - Spud Nut & Escutcheon - 71051Nt6
 - Sweat Solder Kit - TH559EDVSJ3

Optional Accessories:

- Transformer - THU701TR

Meets the American Disabilities Act Guidelines and ANSI A117.1 requirements for people with disabilities.



TET1ANCR-32

AUTOMATIC FLUSHING SYSTEM

TOTO, the world leader in advanced plumbing systems, provides sensor operated flush valves for facilities demanding the finest sanitation equipment for busy restrooms. "Hands-free" technology effectively reduces unsanitary conditions from unflushed fixtures.

SUPERIOR PISTON VALVE

TOTO's piston valve technology is a marked improvement over traditional rubber diaphragm type valves. Longer piston travel and self-cleaning stainless steel debris screen reduce common problems such as continuous running and flooding. The piston seat itself will not warp or mis-seal thus, significantly reducing repair and maintenance costs. A micro-porous cup seal keeps the piston self-lubricated upon each activation with the incoming water supply.

NEUTRAL ROUGH-IN

TOTO's sensor flush valve has neutral rough-in, it can be used as right or left rough-in with no modification.

OPERATING PROCEDURE A sanitary environment without using the hands.



The infrared sensor detects a user sitting on the toilet seat.



After using over 6 seconds, when a user leaves the fixture, the sensor automatically sends a signal to the operating unit to activate the flush valve.

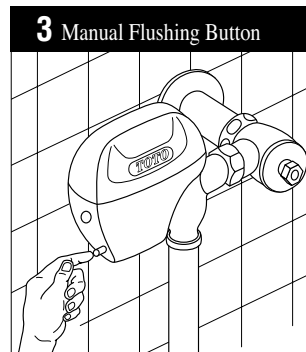

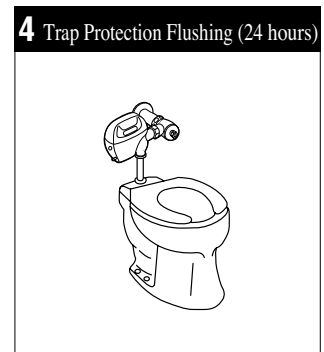

Valve is equipped with a manual flushing button.



AC Powered(120V AC to 10V DC) Sensor Toilet Flush Valve, Exposed

SPECIFICATIONS

Product	TET1ANCR – Valve Only, Left and Right Rough, Chrome Plated Finish TET1ANCR- 32 – Complete Set (1 1/2" V.B.), Left and Right Rough, Chrome Plated Finish
Detection range	Self-adjusting to environment
Detection time	Factory setting at six (6) seconds minimum
Water supply	1" NPT
Discharge quantity	Factory setting at 1.6 GPF/6.0LPF
Toilet type	Flushometer bowl
Trap seal protection	Automatic flushing once every twenty-four (24) hours, if not used
Ambient temperature	32°-104°F (0°-40°C)
Supply water pressure	15 psi - 125 psi*
Transformer	THU701TR Class 2 Transformer - Overload protection provided. Primary voltage: 120V, AC, 60Hz -> 10VDC, 1950mA. Maximum 10 units per transformer
Warranty	Limited three (3) year warranty on all component parts. Details available upon request.
Listings	  A.S.S.E. 1037

*These dimensions and specifications are subject to change without notice.
Water pressures over 80 psi are not recommended for most plumbing fixtures.

SUGGESTED ENGINEERING SPECIFICATION:

TOTO Model No. _____
Automatic infrared sensor activated, bronze piston toilet flush valve. Heavy-duty zinc die cast cover with nickel-chrome finish. Vandal resistant hex head screws. 10V DC power

source required. 1.6 gallon flush with manual override button. Piston valve with solenoid self-cleaning. Automatic flush every twenty four hours if not used. Angle stop and vacuum breaker included.

DIAGRAM:

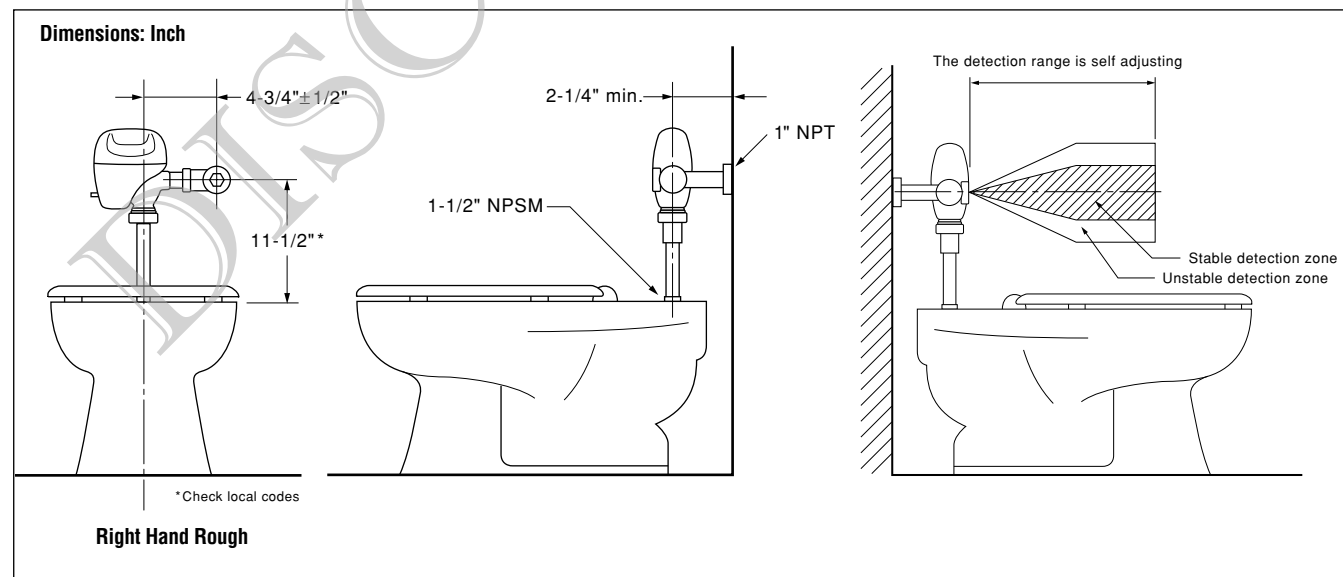

TOTO[®]
Perfection by Design

TOTO U.S.A., INC. • 1155 Southern Road, Morrow, GA 30260
Tel. (770) 282-8686 • Fax. (770) 282-8701 • www.totousa.com
Printed in U.S.A. © TOTO LTD. 11/02 #H80095

Printed on recycled paper 

REV 11/02