

TOTO®

Perfection by Design

Battery Powered (6V, DC) Sensor Toilet Flush Valve, Exposed - 3.5 GPF

To be specified:

Sensor Toilet Flush Valve

- Valve body made of bronze finish
 - Left and Right Rough - TEW1DNCR
- Complete Set, Nickel Chrome Plated Finish
 - Left and Right Rough - TEW1DNCR-32 (1 1/2" V.B.)

Complete set supplied with:

- Vacuum Breaker & Angle Stop Set - VB9CP-32
 - 1" Angle Stop - 10077t3
 - 1 1/2" Vacuum Breaker - 10075t1
 - Spud Nut & Escutcheon - 71051Nt6
 - Sweat Solder Kit - TH559EDVSJ3

Meets the American Disabilities Act Guidelines and ANSI A117.1 requirements for people with disabilities.



4 AA Batteries Included

TEW1DNCR-32

AUTOMATIC FLUSHING SYSTEM

TOTO, the world leader in advanced plumbing systems, provides sensor operated flush valves for facilities demanding the finest sanitation equipment for busy restrooms. "Hands-free" technology effectively reduces unsanitary conditions from unflushed fixtures.

SUPERIOR PISTON VALVE

TOTO's piston valve technology is a marked improvement over traditional rubber diaphragm type valves. Longer piston travel and self-cleaning stainless steel debris screen reduce common problems such as continuous running and flooding. The piston seat itself will not warp or mis-seal thus, significantly reducing repair and maintenance costs. A micro-porous cup seal keeps the piston self-lubricated upon each activation with the incoming water supply.

NEUTRAL ROUGH-IN

TOTO's sensor flush valve has neutral rough-in, it can be used as right or left rough-in with no modification.

OPERATING PROCEDURE A sanitary environment without using the hands.



The infrared sensor detects a user sitting on the toilet seat.



After using over 6 seconds, when a user leaves the fixture, the sensor automatically sends a signal to the operating unit to activate the flush valve.

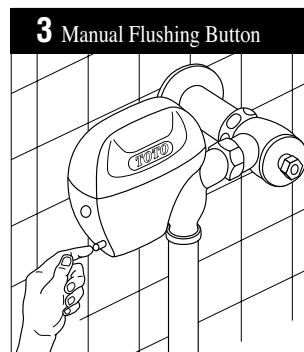

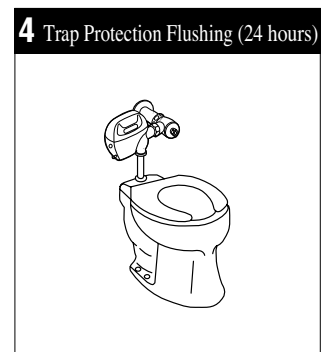

Valve is equipped with a manual flushing button.



Reliance Commercial Line

Battery Powered(6V, DC) Sensor Toilet Flush Valve, Exposed - 3.5 GPF

SPECIFICATIONS

Product	TEWIDNCR – Valve Only, Left and Right Rough, Chrome Plated Finish TEWIDNCR-32- Complete Set (1 1/2 "V.B.), Left and Right Rough, Chrome Plated Finish
Power supply	Four AA alkaline batteries, included. 2-year life, based on 4000 cycles per month
Detection range	Self-adjusting to environment
Detection time	Factory setting at six (6) seconds minimum
Water supply pipe	1" NPT
Discharge quantity	Factory setting at 3.5 GPF/13.2 LPF
Toilet type	Flushometer type bowl
Trap seal protection	Automatic flushing once every twenty-four (24) hours, if not used
Ambient temperature	32°-104°F (0°-40°C)
Supply water pressure	15 psi - 125 psi*
Warranty	Limited three (3) year warranty on all component parts. Details available upon request.
Listings	 A.S.S.E. 1037 

These dimensions and specifications are subject to change without notice.
*Water pressures over 80 psi are not recommended for most plumbing fixtures.

U.S. Patent No. 5008773
5063622
4742583

SUGGESTED ENGINEERING SPECIFICATION:

TOTO Model No. _____
Automatic infrared sensor activated, bronze piston toilet flush valve. Heavy-duty zinc die cast cover with nickel chrome finish. Vandal resistant hex head screws. Four AA alkaline batteries included with a 2 year life at 4,000 cycles/month. Manual

override button included. Piston valve and solenoid with self-cleaning mechanism. Automatic flush every twenty four hours if not used. Angle stop and vacuum breaker included with accessories.

DIAGRAM:

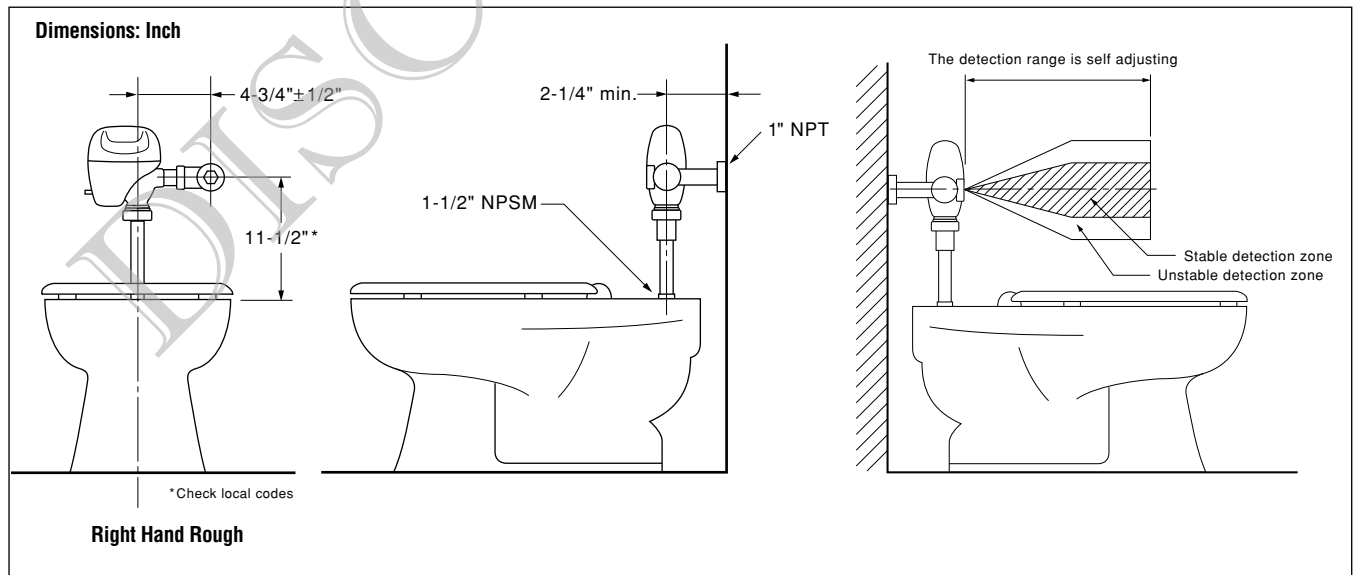

TOTO®
Perfection by Design

TOTO U.S.A., INC. • 1155 Southern Road, Morrow, GA 30260
Tel. (770) 282-8686 • Fax. (770) 282-8701 • www.totousa.com
Printed in U.S.A. © TOTO LTD. 11/02 #H80085

Printed on recycled paper 

REV 11/02