

### FEATURES

---

- Rubber nozzles to prevent limescale build up
- Includes shower elbow and shower holder

### COLORS/FINISHES

---

- #CP Polished Chrome

### OPTIONAL

---

- TS100GR#CP      30" Slide Bar

### CODES/STANDARDS

---

- Meets or exceeds ASME A112.18.1/CSA B125.1
- Certifications: IAPMO(cUPC), State of Massachusetts and others
- Code Compliance: UPC, IPC, NSPC, NPC Canada, and others



### PRODUCT SPECIFICATION

---

Handshower set shall include handshower, holder and shower elbow. Handshower set shall also include hose and have a flow rate of 2.5 gallons per minute. Handshower set shall be TOTO Model TS794F2\_\_\_\_\_.



# TS794F2

## Nexus® Handshower Set

### SPECIFICATIONS

- Warranty Lifetime Limited Warranty (Residential Use)  
One Year (Commercial Use)
- Shipping Weight 3.9 lbs.
- Shipping Dimensions 11-3/4" L x 10-3/4" W x 3-1/2" H
- Maximum Flow Rate 2.5 gpm (9.51 lpm)

### INSTALLATION NOTES

Optional Accessories:  
TS100GR Slide Bar sold separately.

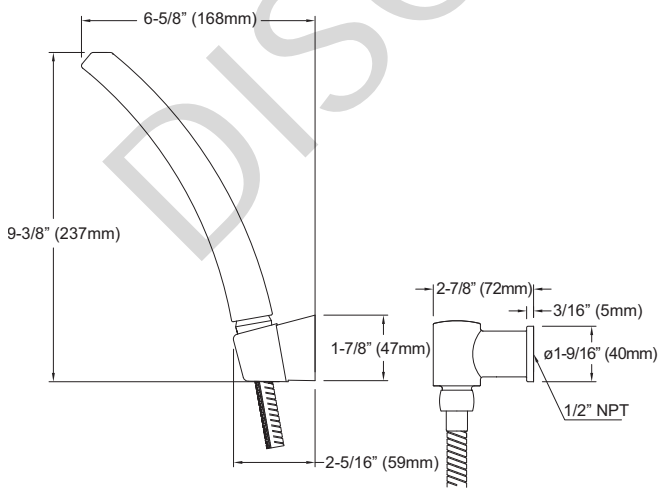
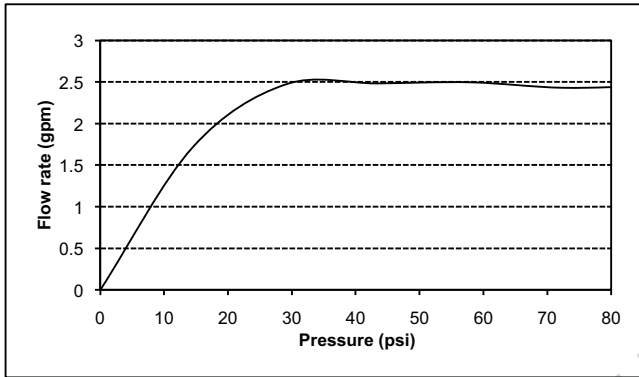

**TOTO®**

*These dimensions and specifications are subject to change without notice*