

IoT-Enabled ECOPOWER® High-Efficiency Toilet Flush Valve, 1.28 GPF

FEATURES

- 1.28 GPF
- Wireless Communication
- Connects seamlessly with Smart Monitoring System and through an API to facilities monitoring platforms
- Service agreement is required to enable IoT or Smart Features
- ECOPOWER flush valve's operation is independent of its IoT capability
- Some of the IoT-enabled Smart Features include: failure detection, usage, water consumption, and battery/capacitor charge
- Self-powered hydroelectric flush valve system
- No minimum daily usage requirement
- 4" x 4" stainless steel cover plate with brushed satin finish and solid bronze valve body
- Self-cleaning piston valve with 360° filter screen
- Neutral rough-in and adjustable tail piece connection
- Manual flush override
- Smart sensor with self-adjusting detection range
- 6 second detection time to prevent ghost flushing
- Concealed flush valve with 1" angle stop and 1-1/2" vacuum breaker set
- Contributes to earning credits in LEED®
- Protects trap seal with a maintenance flush if not used in a 24 hr period

COLORS/FINISHES

- #SS Stainless Steel

OPTIONAL ACCESSORIES

- Z-4000-J - Adapter for ground joint angle stops

MODELS

- TET3LBi2#SS**
TET3LBiA#SS (1.28 GPF flush valve)
THP3395 (IoT Communication Card)
- TET3LBi231#SS (Backspud wall)**
TET3LBiA#SS (1.28 GPF flush valve)
VB1331R#RB (1-1/2" VB tube, 1" angle stop)
THP3395 (IoT Communication Card)
- TET3LBi232#SS (Top spud)**
TET3LBiA#SS (1.28 GPF flush valve)
VB0932R#RB (1-1/2" VB tube, 1" angle stop)
THP3395 (IoT Communication Card)
- TET3LBi233#SS (Backspud floor)**
TET3LBiA#SS (1.28 GPF flush valve)
VB1333R#RB (1-1/2" VB tube, 1" angle stop)
THP3395 (IoT Communication Card)
- TET3LBi4#SS**
TET3LBiA#SS (1.28 GPF flush valve)
THP3566 (IoT Communication Card)
- TET3LBi431#SS (Backspud wall)**
TET3LBiA#SS (1.28 GPF flush valve)
VB1331R#RB (1-1/2" VB tube, 1" angle stop)
THP3566 (IoT Communication Card)
- TET3LBi432#SS (Top spud)**
TET3LBiA#SS (1.28 GPF flush valve)
VB0932R#RB (1-1/2" VB tube, 1" angle stop)
THP3566 (IoT Communication Card)
- TET3LBi433#SS (Backspud floor)**
TET3LBiA#SS (1.28 GPF flush valve)
VB1333R#RB (1-1/2" VB tube, 1" angle stop)
THP3566 (IoT Communication Card)



ECOPOWER



Auto Flush

PRODUCT SPECIFICATION

TOTO® Model No. _____ Product shall be 1.28 GPF. Product shall be an automatic infrared sensor-activated, toilet flush valve. Product shall use hydropower, ECOPOWER flush valve system. Product shall have 4" x 4" cover plate with brushed stainless steel finish and solid bronze valve body. Product shall have smart sensor with self-adjusting detection range. Product shall have neutral rough-in and adjustable tail piece connection. Product shall have manual flush override. Product shall have 6 second detection time to prevent ghost flushing. Product shall have piston with debris screen and solenoid with self-cleaning mechanism.

CODES/STANDARDS

- Meets or exceeds ASSE 1037/ASME A112.1037/CSA B125.37
- FCC compliant to Part 15
- Certifications: IAPMO(cUPC), EPA WaterSense, State of Massachusetts, and others
- Code Compliance: UPC, IPC, NSPC, NPC Canada, and others
- ADA compliant
- Complies with CA Prop 65 warning requirements
- Complies with CA Title 20 regulations and CalGreen when paired with a water closet which has an equivalent water consumption.



TET3LBi Series

IoT-Enabled ECOPOWER® High-Efficiency Toilet Flush Valve, 1.28 GPF

SPECIFICATIONS

Material	Bronze casting
Power supply	ECOPOWER
Sensor detection time	Factory setting at six (6) seconds minimum
Sensor detection range	Self-adjusting to environment
Discharge quantity	Preset to 1.28 GPF / 4.8 LPF
Operating temperature	32-104°F (0-40°C)
Water source	Tap water (Municipal Supply Only)
Water supply pressure	Min: 25 psi (flowing) Max: 125 psi (static)
Water supply connection	1" NPT
Warranty	Three year limited

*Water pressures over 80 psi are not recommended for most plumbing fixtures. Check your local plumbing code for details.

INSTALLATION NOTES

For commercial applications only.

Warning: Failure to properly adjust angle stop to the appropriate level can potentially cause property damage. For detailed installation instructions, please refer to the installation manual.

Max flow rate to be used with TET3LBi _____: 1.28 GPF

Confirm with local codes and standards for floor drain requirement. Adjust control stop for proper flow rate to the fixture.

The flush valve must remain accessible for maintenance and service purposes. An access panel at least 12" x 12" or a walk-in chase is required.

The flush valve requires a minimum of 7" (178mm) depth in the wall.

Do not place grab bars in front of sensor for ADA stalls. A minimum of 13/16" (20mm) clearance around the controller case is required for IoT communication card installation. Please refer to the diagram below.

DIMENSIONS

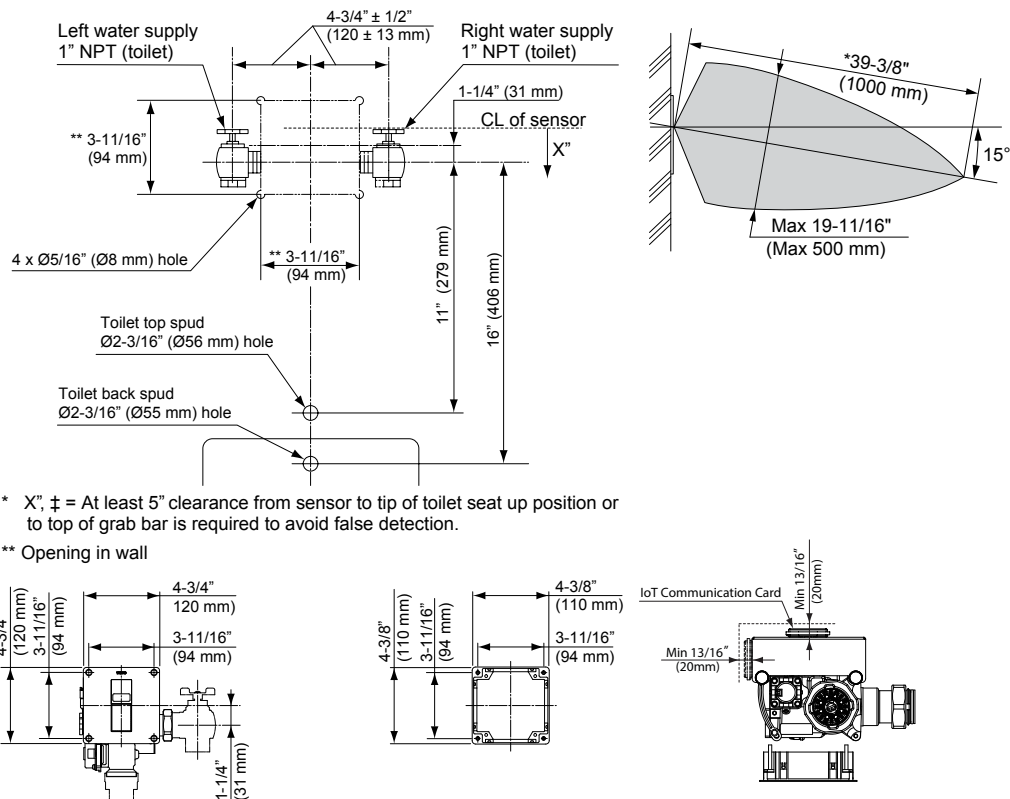

* X, ± = At least 5" clearance from sensor to tip of toilet seat up position or to top of grab bar is required to avoid false detection.

** Opening in wall

TOTO®

These dimensions and specifications are subject to change without notice